

FOREWARD

Dear users:

Sincerely thank you for choosing the BD500-30 two wheeled riding motorcycle designed and produced by our company! This car is independently developed and produced by our company, combining advanced technology and avant-garde design concepts at home and abroad. We hope that it can bring you a safe driving process and comfortable driving experience!

Before driving a motorcycle, please fully read the various regulations and requirements proposed in this practical manual!

This manual provides an overview of the repair and maintenance of this motorcycle. Please follow the various procedures in this manual for operation!

Our company has dedicated technical maintenance personnel and departments to provide you with excellent technical maintenance service support!

The company has always adhered to the service tenet of "making consumers more satisfied" and continuously improves product quality and performance. Any changes in appearance, color, and structure that may arise from this may result in inconsistency with this manual. We apologize for any inconvenience caused. The pictures in this manual are for reference only, please refer to the actual product for details.

Thank you again for your attention and trust in our company!

BENDA MOTORCYCLE

Important precaution

Please operate and drive according to this user manual, strictly abide by national and local traffic laws and regulations, and always pay attention to safety!

This user manual is one of the essential accessories of this vehicle. When the vehicle is resold to others, please attach it with the vehicle.

The copyright of this user manual belongs to Hangzhou Saturn Technology Co.,Ltd,Reproduction is not allowed without the written consent of our company, and violators will be held accountable.

The preparation of this user manual complies with the provisions of GB/T9969-2008 and GB/T19678-2005 standards.

Danger/Warning/Caution

Please read the content of this manual and remember the key points inside.

 **Warning:**

The items indicated by this word indicate precautions for operation to avoid damage to the motorcycle.

 **Warning:**

The items indicated by this word indicate precautions for operation to avoid damage to the motorcycle.

 **Attention:**

The item indicated by this word is a specialized explanation designed to facilitate maintenance or make important instructions more clear.

Content

Forward	1
I、 User notice	1
1.1 Safety instructions for motorcycle drivers	1
1.2 Number position (FIG 1)	1
II、 Introduction to motorcycles	2
2.1 Range of application of BENDA two wheeled motorcycles	2
2.2 Characteristics of BENDA Two wheeled Motorcycle	2
2.3 Carrying regulations	2
2.4 Fuel	2
2.5 Electrical equipment	2
2.6 Inspection	2
III、 Safe driving motorcycles	3
3.1 Safe driving rules	3
3.2 Safety protection equipment	3
3.3 Refitting	3
3.4 Accessories	4
IV、 Operation instruction	5
4.1 Parts position	5
4.2 Instrument	6
4.3 Ignition switch lock, steering switch, seat lock	7
4.4 Right switch combination (Fig 7)	8
4.6 Headlight Pitch angle adjustment (Fig9)	9
4.7 Opening method of fuel tank cap (Fig10)	10
4.8 Tire	10
V、 Operation guide	11
5.1 New vehicle running in	11
5.2 Inspection before driving	12
5.3 Start of motorcycle	12
5.4 Driving motorcycles	14
5.4.1 Shift operation (Fig14、 Fig15)	14
5.4.2 Climbing or turning driving (Fig15)	15
5.4.3 Use brakes	15
5.4.4 Park	15
VI、 Maintenance and upkeep	16
6.1 Maintenance cycle table	16
6.2 Inspection, selection, and replacement of engine lubricating oil	17
6.3 Selection and replacement of spark plugs	19
6.4 Cleaning and disassembly of air filters	20
6.5 Check and adjust of throttle handle	21
6.6 Adjustment of clutch	22
VII、 Inspection and adjustment of belt	22
VIII、 ABS/Anti-lock braking system	23
8.2、 Turning off and on the ABS function	23
IX、 Check and adjust of front brakes	24
9.1 Check the front brake discs	24
9.2 Check the brake pads of the front brake	25
9.3 Check the brake fluid level of the front brake system	25

X、 Check and adjustment of rear brake	26
10.1 Check rear brake disc	26
10.2 Check the brake pads of the rear brake	27
10.3 Check the brake fluid level of the rear brake system	27
XI、 Battery maintenance	28
XII、 Engine water cooling system maintenance instruction	30
XIII、 Vehicle cleaning and storage	31
XIV、 The service life and vehicle handling of vehicles	32
XV、 Adjustment data related to motorcycles	33
XVI、 Table of Main technical parameters	33
XVII、 Common motorcycle troubles and causes	35
XVIII、 BD500-30 Electrical schematic diagram	38

I、 User notice

1.1 Safety instructions for motorcycle drivers

For your personal and vehicle safety, please comply with the following six regulations:

①、 Properly wear various protective equipment

The protective equipment for cycling includes safety helmets, goggles, knee protectors, elbow protectors, and gloves.

Wearing protective equipment can greatly reduce the harm to the body when accidentally falling a car, and can maximize the protection of your personal safety.

②、 Familiar with vehicle construction

The driver's driving skills and understanding of the vehicle are the foundation of safe driving. Before officially riding a bicycle on the road, it is necessary to practice in an open area without other vehicles and be fully familiar with the vehicle and its handling methods.

③、 Understand the limit of one's safe speed

The driving speed depends on the ground conditions, your own skills, and the weather. Drive at a safe speed and within your skill range at all times. Understanding this limit will prevent accidents from occurring.

④、 Wear appropriate clothing

Loose and bizarre clothing can make driving uncomfortable and unsafe. Wearing suitable clothing on the saddle will allow you to move your hands, feet, and body freely. Therefore, try to choose high-quality tight fitting clothing.

⑤、 Inspection before driving

Please carefully read the instructions in the "Pre driving Inspection" section of this manual, and driving according to the rules can ensure the safety of you and passengers.

⑥、 Double attention to safety when driving on cloudy and rainy days

Pay special attention in rainy days. Remember that the Braking distance is twice as long as in sunny days. When driving, keep away from the hole cover, marking paint and greasy road surface to avoid skidding.

1.2 Number position (FIG 1)

①、 Vehicle frame number (VIN): Front end of the right frame (right side of the front pipe);

②、 Nameplate: Front end of left frame (left side of front pipe);

③、 Engine number: directly above the left side of the engine box;

Location map of nameplate, chassis number, VIN code, and engine number

Please fill in the frame and engine code below for future reference:

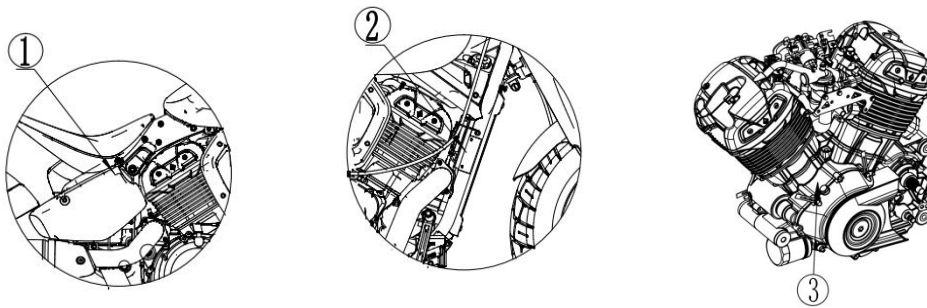

VIN	
Engine No	

II、 Introduction to motorcycles

The motorcycle has a compact structure, unique style, novel appearance, good driving stability, and comfortable riding. Adopting an electronic fuel injection system, it is more environmentally friendly and efficient, meeting national emission requirements.

2.1 Range of application of BENDA two wheeled motorcycles

BD500-30 is a self-developed two wheeled motorcycle, which is suitable for both urban roads and rural roads.

2.2 Characteristics of BENDA Two wheeled Motorcycle

- 1、 Strong power and heavy load
- 2、 High torque, strong climbing ability
- 3、 Electronic fuel injection system
- 4、 Advanced, professional water cooled engines in China
- 5、 Full DC power supply system

2.3 Carrying regulations

Number of passengers: 1 (including driver)

Maximum allowed load capacity: 75kg。

2.4 Fuel

Fuel grade: 92 octane or above unleaded gasoline.

Due to the flammable gasoline, If the fuel tank、 fuel filter、 fuel pipe、 throttle valve body and components leak due to damage or aging, they must be repaired in a timely manner before use.

Unleaded gasoline can extend the service life of spark plug and mufflers.

2.5 Electrical equipment

You are not allowed to install and change wiring of this vehicle on your own, nor can you modify electrical equipment on your own. Otherwise, it will overload the electrical system, causing the circuit to overheat, causing fuses to melt or the circuit to short-circuit, and even generating sparks, causing danger such as burning the car.

⚠ Danger:

Our company shall not be responsible for any consequences caused by the installation or modification of our vehicle's wiring or electrical equipment.

2.6 Inspection

You should strictly follow the requirements in the "Maintenance Schedule" to maintain your vehicle.

III、 Safe driving motorcycles

This motorcycle is a two wheeled motor vehicle can bring convenience and speed to rider,To ensure your motorcycle' best performance,you should compliment the correct maintenance and upkeep .When using the motorcycle,it must be safe and normal;when driving or riding it,your body must be healthy so that you can drive the vehicle at your best condition.

⚠ Danger:

Driving a motorcycle must comply with traffic regulations; Before driving, the vehicle must be carefully inspected.

3.1 Safe driving rules

- 1、 It is necessary to inspect the motorcycle is safe and normal carefully before starting the motorcycle.This can avoid accidents and damage the components.
- 2、 Motorcycle drivers must pass the traffic management and obtain the motorcycle driving license.Do not lend motorcycles to people without a "motorcycle driver's license" for use.
- 3、 To avoid harm you should:
 - Wear eye-catching clothing
 - Do not drive too close to other vehicle and use signals as turn signals, horns and brake lights.
 - Please do not drive in the blind spot of other drivers.
- 4、 Comply with traffic rules strictly
 - Speeding is the main factor leading to motorcycle accidents.If encountering rainy and snowy weather and gravel roads, intersections and other road conditions.It is necessary to drive at low speed and slow down carefully.
 - When turning and changing lanes , signal device such as turning signals must be turned on to attract drivers' attention.
5. Drivers should hold the steering handle tightly with both hands and step on the front pedals with both feet; Passengers should tightly grasp the armrest or hold the driver's waist with both hands, and step on the rear pedals with both feet.

3.2 Safety protection equipment

- 1、 Most the injuries of motorcycle accidents are head injuries.Therefore drivers and passengers must wear helmets that meet safety and quality standard as well as dust proof glasses and gloves.
- 2、 When driving,exhaust muffler's temperature is so high, to avoid contact burns, both drivers and passengers should wear long boot and other equipment.
- 3、 Do not wear loosen clothing to prevent accidents from catching the steering handle , clutch handle, pedals or nearby vehicle.

3.3 Refitting

⚠ Warning:

1. Arbitrary modification of the motorcycle or replacement of the original device cannot guarantee the safety of the motorcycle and is illegal. You must comply with the regulations of the traffic management department on the use of the vehicle.
- 2.To ensure that the exhaust emission can meet the national emission requirements, you cannot modify or remove the following parts without authorization.
 - (1) You cannot adjust the idling speed at will;
 - (2) As the exhaust muffler is equipped with optimized catalyst, if the exhaust muffler is damaged, please go to the designated maintenance unit for repair or replacement.
- 3.If there is a good modification suggestion, you can write to our company, and our company will be specifically responsible for the implementation after confirmation. The company will not be responsible for any unauthorized modification that may lead to undesirable consequences.

⚠ Danger:

We will not be responsible for any dangerous consequences such as short-circuiting of wires, blowing of fuses, burning of the car due to exceeding the rated power of electrical appliances or generating of sparks if you modify the cables and electrical appliances by yourself.

⚠ Attention:

Improper or overweight loading of motorcycle cargo will affect the performance of the vehicle, reduce its driving stability, and easily cause safety accidents.

The modification or removal of original parts from motorcycles may result in reduced safety or illegal driving of the vehicle. Please follow all regulations in your region.

When loading goods:

- 1、 The goods should be loaded at the center and lower, close to the center of the vehicle.
- 2、 Adjust the pressure of tire according to load weight and drive conditions.
- 3、 All goods should be fixed on the vehicle firmly to ensure the stability of control.
3. Do not attach large or heavy objects to the steering handle, front shock absorber, or front mudguard, as this may cause unstable driving or poor steering.
- 5、 It is strictly prohibited to exceed the maximum loading weight of 75kg.

3.4 Accessories

All accessories pass the test. Therefore our company is not responsible for any adverse consequences caused by installation of non original accessories.

You should inspect them carefully if install the non original accessories: visual impairment, ground clearance, lateral tilt angle, steering flexibility of control mechanism, ease of operation, performance of accessories.

IV、 Operation instruction

4.1 Parts position



图 1

1、 (Fig1)

- ① Front headlight
- ② Front left turn signal
- ③ Front left mirror
- ④ Battery (Battery box inside the protective panel)
- ⑤ Seat cushion
- ⑥ Rear left turn signal
- ⑦ Rear license plate light
- ⑧ Front Brake Caliper
- ⑨ Shift lever
- ⑩ Front left foot pedal
- ⑪ SIDE STAND

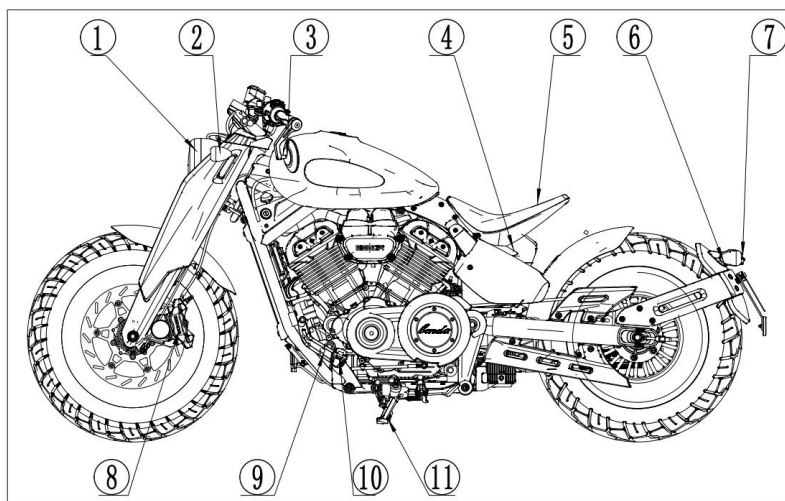
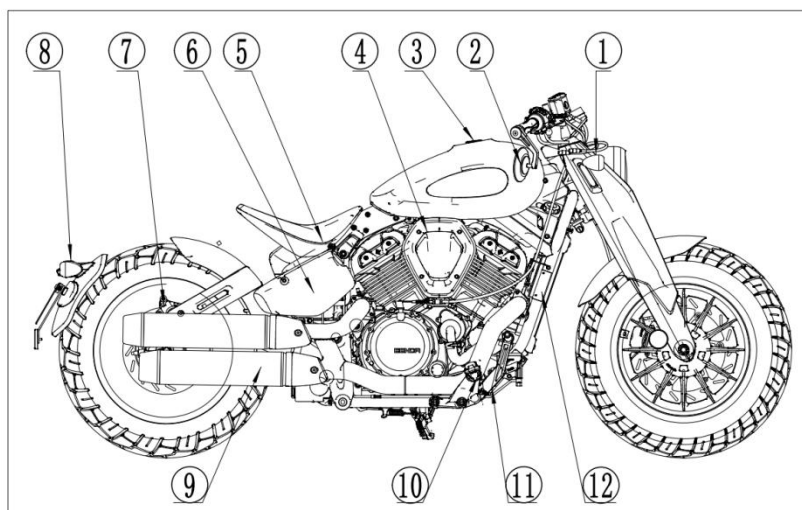

2、 (Fig2)

- ① Front right turn signal
- ② Right rear mirror
- ③ Fuel tank cover
- ④ Air filter
- ⑤ Frame VIN code
- ⑥ Rear shock absorber (under the protective plate)
- ⑦ Rear brake caliper
- ⑧ Rear right turn signal
- ⑨ Exhaust muffler
- ⑩ Right foot pedal
- ⑪ Brake pedal
- ⑫ Nameplate

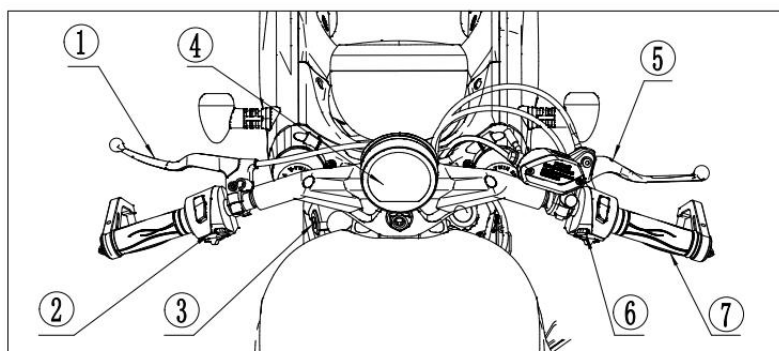

3、 Front car body (Fig3)

- ① Clutch handle
- ② Left switch combination
- ③ Ignition lock
- ④ Instrument
- ⑤ Front brake handle
- ⑥ Right switch combination
- ⑦ Throttle lever sleeve

4.2 Instrument

Instrument (=FIG4)

Please refer to Table 1 for the names and functions of indicator light symbols

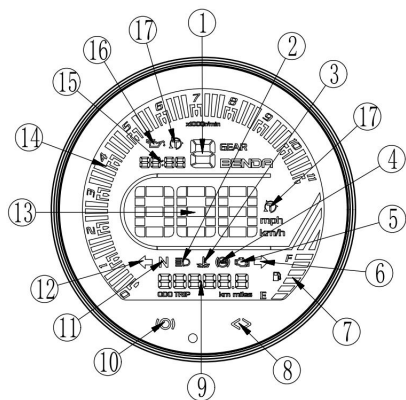

Fig4

No	Name	Function
1	Gear display	Display the location of the engine
2	High beam indicator	The high beam light is on, and when it is lit, it displays blue
3	Water temperature alarm indication	Illuminate and display in red: coolant overheating, cooling system malfunction
4	ABS indicator	Display ABS status
5	Electronic fuel injection malfunction indicator light	After the engine is running, the light will turn off. If there is a fault, it will display a yellow light flashing
6	Right turn indicator	The front and rear right turn signals flash, and when illuminated, they display green
7	Fuel quantity indicator	Display the remaining fuel in the fuel tank
8	Right touch button	Details can be found below
9	Mileage display	The total mileage traveled by the vehicle
10	Left touch button	Details can be found below
11	Neutral indicate	Illuminates green when in neutral
12	Left turn indicate	Illuminates green when front and rear turn signal flashing
13	Speed indication	Instantaneous speed
14	Rotational speed indication	Illuminate instantaneous speed of engine
15	Time/oil pressure fault indication	Display current time/oil pressure fault (E-01)
16	Oil pressure indicator	The light comes on when there is a malfunction in the oil pressure
17	TCS indication	Display TCS status

Tips: “Left touch key” Switch between total and subtotals of driving mileage during a single press. When in subtotal mode, press and hold the left touch button to reset the subtotal mileage to zero.

Long press the right touch button enter into clock setting mode, at this time, press the “right touch button” once to switch the required adjustment position of the clock. Single press “left touch button” can adjust the time.

4.3 Ignition switch lock, steering switch, seat lock

Ignition switch (Fig5) set in the front left of the vehicle, it must be turned on before starting the motorcycle. Key positions and functions are shown in Fig2.

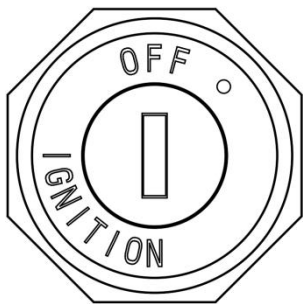
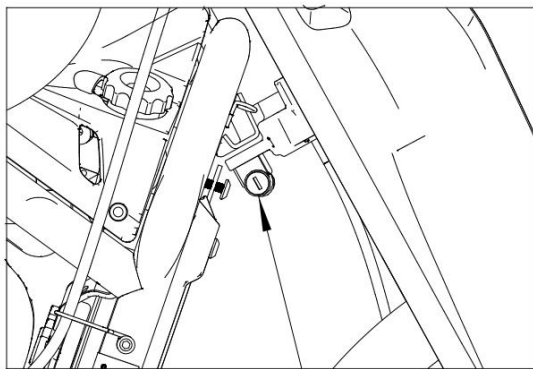

Fig5

Key position	Function	Key status
Close "OFF"	Circuit disconnected ,engine unable to start	Can be pulled out
Open "O"	The circuit is closed and the engine can start	Can not be pulled out
<p>⚠Attention: 1. When not use the vehicle,turn the key to "OFF"position and remove the key</p>		

Table2

Steering lock (Fig 6) Installed at the lower link board. Lock the steering mechanism when parking and not in use.



Steering lock

Fig6

⚠Attention:
Before locking the steering mechanism , The vehicle needs to be parked properly.After locking ,the motorcycle can not be pushed ,making it difficult to balance and prone to rollover

4.4 Right switch combination (Fig 7)

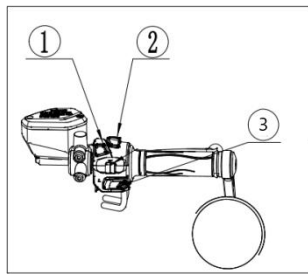



Fig7 Right switch combination

- ① Hazard warning flasher
- ② Turn off preset switch
- ③ Electric start button

1、Flame-out preset switch

Flame-out switch located on the right of the steering lever, preset switch has two position: “” and “”

Turn off “  ”	Turn off the ignition switch-At this position, the ignition circuit is disconnected, The running engine is turned off and cannot be started.
Turn on “  ”	Turn on the ignition switch - it needs to be switched to this position during operation, and the ignition circuit has been closed.

2、Electronic start button

Ways: After doing the start preparation (Page 7), press on the electronic start button “”, If necessary simultaneously rotate the throttle lever to add fuel appropriate then you can start the engine.

(Fig9)

4.5 Left switch combination (Fig8)

- ① Overtaking light switch
- ② ABS function switch
- ③ High and low beam switch
- ④ TCS function switch
- ⑤ Horn switch
- ⑥ Turn signal switch

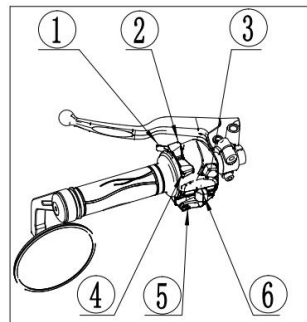

Fig8 Left switch combination

1、Overtaking light switch

When the "overtaking light button" is pressed, the overtaking light will light up;





When the "overtaking light button" is released, the overtaking light does not light up.

⚠ Attention:

The current headlight is in high beam mode “”, Overtaking lights do not work.

2、Head light dimmer switch

Head light dimmer switch has two running state: Turn on the ignition switch lock, And “Head light、 position light switch” move to “” this position.

Low beam “  ”	“Head light dimmer switch” move to “  ” is low beam status
High beam “  ”	“Head light dimmer switch” move to “  ” is high beam status

⚠WARNING:

Please adjust the high or low beam according to road condition. If there are oncoming vehicles, please turn the light to the low beam light state to avoid dazzling light affecting the driving state of oncoming drivers and causing traffic accidents.

3、Turn signal switch

When turn left, move “turn signal” to “”; Front and rear turn signal light of left, the left turn indicator light is on of the instrument.

When turn right, move “turn signal switch” to “” position; Front and rear turn signal light of right, the right turn indicator light is on of the instrument.

Move the turn light switch to middle position: Then left, right turn light and indicator light are not light up.

⚠Warning:

When turn or change the lane we must turn on the turn signal switch, And turn off the turn signal till finish turning or changing the lane.

4.6 Headlight Pitch angle adjustment (Fig9)

Due to user’s height and observation habits, So have different requirements to light for night time drive. To give the user a better drive experience in night, The front headlight was designed specially with a adjustable angle. User can adjust according to self need. Ways as followings:

The first step、Use 6# Hex key、10# open spanner loosen the upper and lower fixing screws that secure the front headlights

The second step、After loosening the screws .Rotate the light with lower fixing screws as the axis ,then adjust to proper position and fasten the screw.

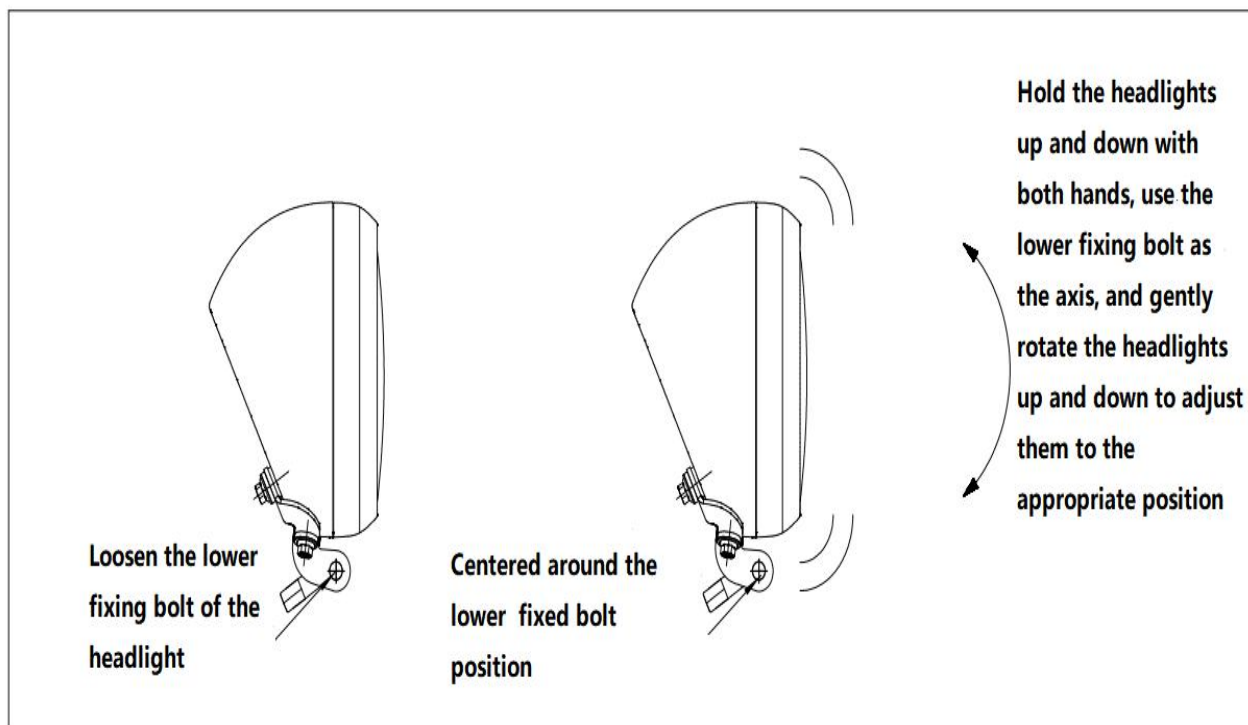

Fig9

⚠ Attention:

Headlamps have no pitch angle limiting structure. Please adjust according to actual needs.

4.7 Opening method of fuel tank cap (Fig10)

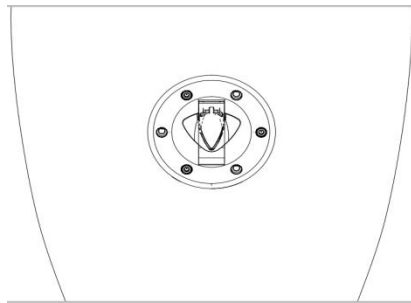

Fig10 Fuel tank cover

Open the small cover that covers the keyhole, insert the key into the fuel tank lock hole, and rotate clockwise to open the fuel tank lock; When closing, remove the key, gently close the fuel tank cap, and press firmly until you hear a "click" sound. Finally, cover the small lid that covers the keyhole.

4.8 Tire

Correct tire pressure will ensure: stable driving、comfortable driving、endurable tire.Tire pressure should inspect at cold tires.

Tire specification and pressure referenced to Fig 3 :

Cold tire pressure	Single			Double		
	kPa	kgf/cm2	psi	kPa	kgf/cm2	psi
Front wheel	225	2.25	33	225	2.25	33
Rear wheel	225	2.25	33	225	2.25	33

Table3

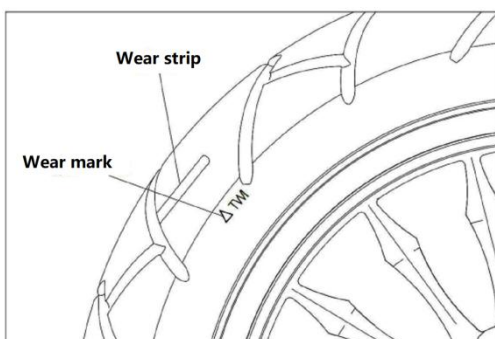

Fig11 Inspection of the tire

Determine tire state.Incorrect tire specification will influence manipulate performance.Damage and wear on the tire will lead to the tire lose control.Over wear of the tire will lead to perforation and lose control.Tire's wear also influence appearance and manipulate performance.

Inspect the state and pressure of the tire before using.If many obvious wear like wear,scratch or worn to their limit position,must change the tire.

⚠Attention:

- 1、 When pressure of tire decline , Inspect if have nail,small hole on the tire.Is the side of the wheel rim damaged.
Tires without inner tubes will gradually deflate when they have small holes.
- 2、 Incorrect pressure of tire will lead to abnormal wear of tire tread ,Even causing safety accidents.
- 3、 Insufficient tire pressure may cause tire damage or detachment from the wheel hub.

⚠Warning:

- 1、 The triangular mark indicates the position of the wear strip.If wear strip touch the ground,that means tire has reach to the limit and should change the tire.
- 2、 When change the tire , determine the size and type of tire should accord with table 3.If change the tire of different size or type,it will affect the performance of manipulating the motorcycle and cause it lose control.
- 3、 After repairing or changing the tire , we should balance the wheel which is very important.Because it can avoid the touch between tire and ground , also avoid some uneven wear.

⚠Danger:

- 1、 Sealing of tubeless tires at the contact area between the rim and tire lip.To avoid air leak, Disassembling and installing tubeless tires requires special tools to protect the rim and tire lip, using a specialized tire disassembly and assembly machine.
- 2、 Repair the small hole of tubeless tire need dismantle the tire and apply the patch inside.Do not use external repair method. Because when turning,the centrifugal force of the tire can loosen the repaired area.The centrifugal force will cause the loosen of repair position 。 Within 24 hours of repairing the tires.Speed can not over 80km/h,later the speed can not over 130km/h.If over speed,The heat generation of tire increase sharply, will render the repair ineffective,cause tire air leakage.If side of tire damaged , or position of tire damaged over six millimeters , the tire can not be repaired to

V、 Operation guide

5.1 New vehicle running in

Run-in period is the initial period of use of the new vehicle,a method to ensure that the bonding surface between parts becomes the optimal bonding state.Correct run in operation can improve the life time of vehicle to the maximum extent possible.

New vehicle run in mileage: 1500km

1、 In the running in period : Throttle should be avoided full open,Engine's maximum speed can not exceed 6500 rpm(Instrument): Speed should be controlled within the following range

0~300km Run in :

Throttle handle should be opened to avoid exceeding 1/2 of the maximum opening; Vehicle speed within 50km/h.

300~600km Run in:

Throttle handle should be opened to avoid exceeding 2/3 of the maximum opening; Vehicle speed within 60km/h

600~1500km Run in:

Throttle handle should be opened to avoid exceeding 3/4 of the maximum opening; Vehicle speed within 70km/h.

2、 Avoid sustained low speed: Engine runs at a certain low speed (light load) ,Will cause smooth grinding of components and poor running in.

3、 Use every gear properly: Do not drive Continually at a fixed speed of engine,Can change the speed ,enable every components of engine to undertake pressure, Which can make the engine run in better.

4、 Before driving,first circulate the oil: After start the hot or cold engine,before operating without applying load to give the engine sufficient idle time,this can lubricate all important components of the engine with oil.Reduce the wear, prolong the life time and can also preheat the engine.

5、 New tire's run in: Tire also need to be run in,Before running in the new tire,Within 160 km you should increase the turning inclination angle,but avoid sudden braking rapid acceleration sharp turns.

6、 Run in period repair: Please repair when driving the new vehicle over 1000km,In the run in period, other parts have already engaged.This time all components should be adjusted properly Then change the oil.

⚠ Danger:

Poor tire running in will cause slip or lose control.When using new tire should be very careful,Run in the tires within the first 160 kilometers (100 miles)

⚠ Attention:

When the vehicle is in poor condition, it needs to be repaired before 1000 kilometers.

5.2 Inspection before driving

To ensure driving safe,please check this vehicle before using it; If there are any abnormal phenomena during the inspection, they must be repaired and resolved before use.

The following procedures can be followed for inspection:

1. Check the lubricating oil inside the engine (see page 16) and ensure that there are no leaks;
2. Check if the fuel is sufficient;
3. Check if the coolant in the cooling system is sufficient and ensure that there are no leaks;
4. Check the front and rear brakes: free travel (5-10mm in the front and 10-20mm in the back), smooth operation;
5. Check the front and rear tires: air pressure, depth of tread wear, cracks (see page 10);
6. Check the transmission belt: the tightness is suitable, there are no defects or damage;
7. Check the throttle handle: free clearance (2-6 mm), and whether refueling or refueling is easy to operate;
8. Check the lighting and signal lights: ensure that the headlights, tail lights, brake lights, turn signals, indicator lights, and horns are in good condition;
9. Check the battery electrolyte and add distilled water in a timely manner (see page 24);
10. Check the steering device: it should be stable, rotate flexibly, without looseness or axial movement;
11. Check the clutch handle: free clearance (5-10mm) and smooth operation;
12. Tightening bolts and nuts: front and rear shock absorbers, wishbones, front and rear wheel axles, engine suspension, steering system, steering lever, front and rear brakes, clutch, rear suspension system, electrical components, etc.

⚠ Warning:

No inspection before driving and proper maintenance will leave safety hazards behind.Inspecting motorcycles before riding can eliminate safety hazards.

5.3 Start of motorcycle

(Fig13)

- 1、 Turn on the ignition lock,move the flame-out preset switch to “” position.
- 2、 Shift the gear to low or neutral.

3、 Fully grip the clutch lever with the left hand (release the clutch when not in neutral).

4、 Press on the electronic start button“(⚡)”,if necessary, turn the throttle handle and add fuel appropriately to start the engine.

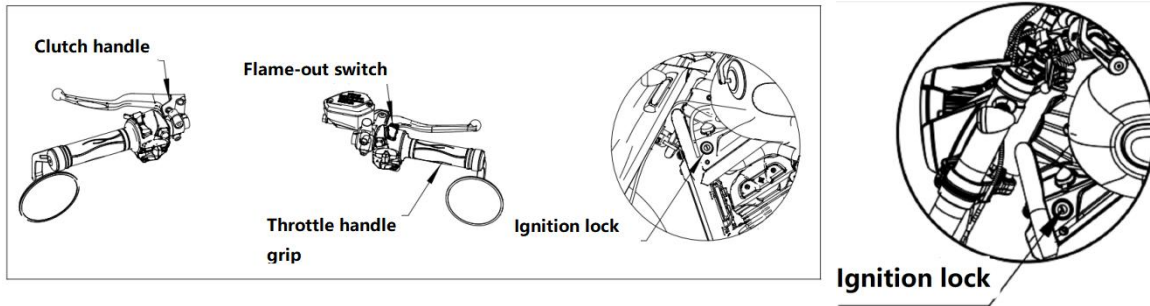

Fig13 Start preparation

⚠ Danger:

1. To avoid errors and danger caused by rushing forward during startup, shift to neutral and do not use the fuel door.
2. When not driving, the engine speed should not be too high and the idle time should not be too long, otherwise it may cause the engine to overheat and damage internal components, and cause discoloration of the exhaust pipe muffler.

⚠ Danger:

1. If you are driving this type of vehicle for the first time, we suggest that you practice on a non-public road until you become familiar with the control and handling methods of this vehicle.
2. One handed driving is the most dangerous, one should firmly grasp the steering wheel with both hands and place both feet on the pedals while driving. Regardless of the situation, do not drive with both hands off the handlebars.
3. Reduce the speed to a safe speed before turning.
4. The road surface is damp and smooth, and the tire friction is low, resulting in a natural decrease in braking and turning ability. Therefore, it is necessary to slow down in advance.
5. Cross winds are usually most likely to occur at tunnel exits, valleys, or when large vehicles overtake from behind. You must be careful and calm, slow down while driving.

⚠ Attention:

1. After starting, it should be preheated for 2-3 minutes before driving on the road. An engine with insufficient preheating temperature will exacerbate the wear of components such as cylinders, piston rings, and rocker arms during operation.
2. When using the electric start button, it should be immediately released within 3-5 seconds of each operation; Otherwise, it is easy to cause the battery to discharge too quickly and affect the service life of the battery.
3. After the engine starts, the electric start button should be immediately released; When the engine is running, it is not allowed to press the electric start button again, otherwise the engine may be damaged.
4. Ensure that the single brace is fully retracted to avoid driving obstruction and control failure when turning left.
5. After starting or during driving, it is necessary to refuel smoothly (by turning the throttle handle).
6. Do not start the motorcycle in a narrow space to avoid the risk of poisoning caused by the difficult diffusion of exhaust gases.
7. If the clutch switch fails, it should be replaced in a timely manner.
8. It is strictly prohibited to start the engine before the clutch is disengaged, otherwise it may cause component damage or safety accidents.
9. Do not start the motorcycle when there is a lack of fuel or oil.

5.4 Driving motorcycles

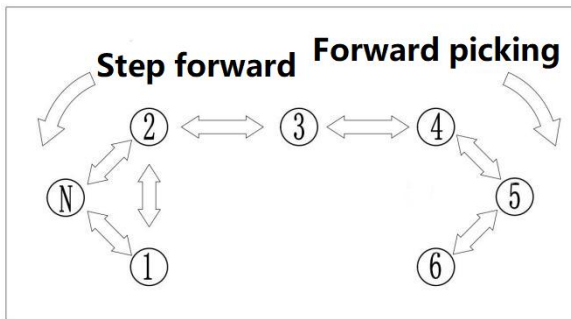

Fig14 Shift position

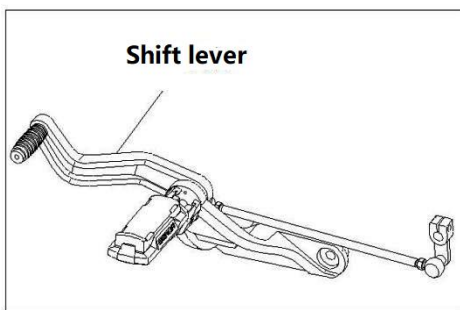

Fig15 Shift lever

5.4.1 Shift operation (Fig14, Fig15)

This vehicle has a six speed constant engagement; ①、②gear are low speed,③、④gear are medium speed,⑤、⑥gear are high speed.Gear shifting can refer to the following operations:

1) Shift from neutral to ① gear: Return the throttle with the right hand, quickly grip the clutch handle with the left hand, and press down on the gear lever with the left foot once,Enable the transmission into①gear,Gradually release the clutch handle with the left hand and gradually fill the fuel door with the right hand.Action coordinate and enable the motorcycle ride smoothly at ① gear.

2) ①gear to②gear : Right hand throttle return, Quickly grip the clutch handle with your left hand and hook the gear lever up with your left foot once , making the transmission into ② gear,Gradually release the clutch handle with the left hand , Right hand gradually refueling door 。 Good coordination of movements.Enable the motorcycle drive at a stable ② gear.

3) The method of shifting from② to ③④⑤⑥ is same to shift ①to②.

4) The method of downshifting is the same as shifting from neutral to ①.

Warning:

- 1、 Do not shift gears without returning the throttle or gripping the clutch lever,otherwise it may cause damage to the engine and transmission system and lead to safety accidents.
- 2、 When shifting gears, please confirm that the gear lever is pressed in place before releasing the clutch lever.
- 3、 When shifting or gripping clutch handle, clutch out.Motorcycles rely on inertia to travel, therefore,minimize the shifting time ASAP.
- 4、 When driving at high speed, suddenly lower the gear or quickly return the throttle,low engine speed and high rear wheel speed. When loosening clutch handle , Friction and engagement deceleration of the clutch pads cause rear wheel braking, Loss of control leading to accident.Therefore.When changing from high-speed to low-speed driving, it must slow down and then lower the gear.
- 5、 Do not use low-gears for high speed driving or high gears for low speed driving.Otherwise it will cause damage of the engine.
- 6、 Before accelerating the gear must be uplifted to allow the engine to operate within the normal speed range.No gear should cause the engine speed to be too high.

⚠ Attention:

- 1、 Before switching the low gear, lower vehicle speed or increase the speed of engine。 Before shifting into high gear, increase the vehicle speed or decrease the engine speed. This can prevent unnecessary wear of transmission system components and rear tires.
- 2、 When the gear is in neutral and the neutral indicator light is on, it is best to slowly release the clutch handle to confirm whether it has truly entered the neutral position

5. 4. 2 Climbing or turning driving (Fig15)

- 1) When driving uphill, there will be a deceleration phenomenon where the gear is too high and the power is insufficient. Therefore, it is necessary to quickly lower the gear before driving uphill.
- 2) When driving downhill, the gear must be lowered, intermittent use of front and rear brakes. If the front and rear brakes are used continuously for a long time, it can cause the brakes to overheat and reduce braking effectiveness, posing a danger.
- 3) When going downhill, do not turn off the ignition switch or the engine flame-out switch to coast, otherwise it will reduce the lifespan of the catalyst inside the exhaust muffler.
- 4) Before turning, you must first use the brakes to reduce the speed and then lower the gear. Otherwise, driving too fast and rushing out of the bend, or using the brakes during turns can cause dangerous accidents.

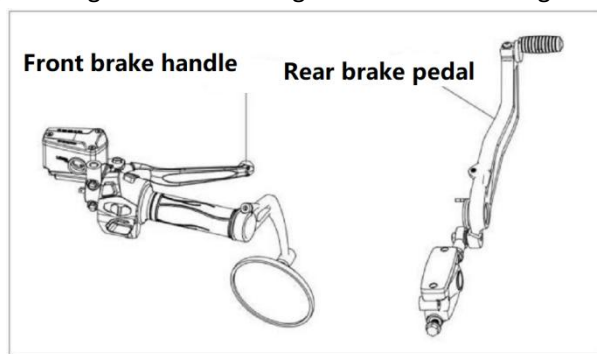

Fig15 Rear brake pedal

5. 4. 3 Use brakes

- 1) When decelerating, both front and rear brakes must be used simultaneously. (Slowly grip the front brake handle with your right hand and step on the rear brake pedal with your right foot to avoid using the front and rear brakes separately). Avoid decelerating too quickly, which may cause clutch slippage.
- 2) In emergency situations, simply turn off the ignition switch and use both the front and rear brakes to stop the vehicle.
- 3) Try to avoid sudden braking. Because sudden braking can cause the front and rear wheels to suddenly stop, making it difficult to control the vehicle.
- 4) Avoid sudden acceleration, sudden braking, and sharp turns on wet or soft road surfaces. Prevent vehicle skidding that is difficult to control.

5. 4. 4 Park

- 1) Gradually return the throttle until it fully returns.
- 2) At the same time, slowly grip the front brake lever with your right hand and step on the rear brake pedal with your right foot to avoid using the front and rear brakes separately.
- 3) When the speed decreases, lower the gear.
- 4) Grasp the clutch handle tightly, shift into neutral, and then come to a complete stop. After shifting into neutral, the

neutral indicator light on the instrument panel lights up.

5) If you want to park on a gentle slope with a single support, you should shift to a lower gear and keep the front of the car uphill to avoid overturning. (Be sure to shift to neutral position when starting again)

6) Turn off the ignition lock; In emergency situations, the engine can be turned off by directly turning off the ignition switch.

7) Lock the steering mechanism and remove the key to prevent theft.

⚠ Danger:

1. The higher the vehicle speed, the longer the braking distance will be. Therefore, it is necessary to maintain a safe distance to prevent rear end collisions. (Frequent use of only the rear brake will accelerate the wear and tear of the braking system, and the braking distance will become longer.)

2. Using only the front or rear brakes can cause slipping and loss of control; Be cautious when using the braking system on slippery roads and when changing lanes; Emergency braking on uneven or smooth roads can cause the motorcycle to lose control.

VI、 Maintenance and upkeep

6.1 Maintenance cycle table

Motorcycles should be regularly maintained according to the time and mileage specified in Table 4, and the vehicle must be cleaned before maintenance.

maintenance frequency Maintenance items	mainte nance period	Odometer km (Note②)				Note
		1000km	4000km	8000km	12000km	
★Fuel tank and oil pipe		Damage and aging should be repaired or replaced in a timely manner				Before using
★Throttle		I	I	I	I	Before using
★Coolant		Change every 2 years				Check before using
Air filter element	Note ①	Every 40 hours of driving or 1000km/I; Every 80 hours of driving or 2000km/C; Every driving 20000km/R				
Spark plug		Every diving 2000km or 80hours/I; Every driving 6000km/R				
Engine lubricate oil		New vehicle replace once at 1000km, Replace when driving 2000km for the second time, Replace every 3000km after the third journey, and thereafter every Replace once after driving around 4000km				
Lubricating oil filter element		New vehicle Replace once at 1000km, replace after the second journey of 2000km, replace after the third journey of 3000km, and replace every 4000km thereafter				
Chain/Sprocket	Note ①	Perform I and L every 500km				
★Brake friction pad		Perform I and, if necessary, R every 1000km				
★★Brake oil		Replace every two years				
★★Front and rear	Note	I	I	I	I	Before using

brake systems	③					
★ Switch		I	I	I	I	Before using
★ Lights and speakers		I	I	I	I	Before using
★ Battery	Every month	I	I	I	I	
Fuses		I	I	I	I	
Connecting lines		I	I	I	I	
★★ Valve clearance	Note ③	Initially: 20 hours or 200km/l; Every 2000km or 80 hours/l				
★ Clutch		Every 2000km or 80 hours/l				Before using
★ Suspension system		I	I	I	I	
★ Tightening of nuts and bolts		I	I	I	I	Before using
★ Wheels		I	I	I	I	Before using
★★ Steering handle bearing (steering column thrust bearing)	Note ③	I	I	I	I	
★★ Engine maintenance	Note ③	I	I	I	I	

The symbol in the table above is: "I" for timely inspection, cleaning, adjustment, lubrication or replacement; "C" cleaning; "R" replacement; "L" lubrication.

No ★ items require your own maintenance, or you can go to the BENDA specialty store for maintenance.

A ★ project is maintained by personnel from a BENDA specialty store; If you have specialized tools, repair parts, or repair capabilities, you can also repair and maintain them yourself.

Two ★★ projects, for the sake of driving safety, can only be maintained by personnel from the BENDA specialty store.

Note ① indicates that when driving in dusty areas, the cleaning cycle should be shortened.

Note ② indicates that when the odometer reading exceeds the highest number in the table, the maintenance and repair cycle will still be repeated according to the mileage specified in the table.

Note ③ indicates that maintenance and adjustment can only be carried out by personnel from BENDA specialty stores.

6.2 Inspection, selection, and replacement of engine lubricating oil

The function of lubricating oil on the engine is to reduce friction, increase sealing, cool parts, clean parts, and prevent rust.

If the quality of lubricating oil is poor, the usage time is too long, or the lubricating oil quantity is insufficient, it will accelerate the wear of engine parts and reduce the service life of the engine; Even causing excessive engine temperature, clutch wear or burning, decreased power, abnormal noise, and burning of lubricating oil.

[Inspection] (Fig17)

Before each use, the lubricating oil level must be checked, and there is oil on the right crankcase cover window.

Start the engine and run it for 3 minutes, then wait for the engine to stop for 3 minutes. Park the motorcycle on a flat surface with the entire vehicle perpendicular to the ground. At this point, the oil level should be between the upper and lower markings on the oil window.

If the lubricating oil is insufficient, directly open the oil filler plug and add an appropriate amount of lubricating oil. After installing the fuel plug, check for any leaks.

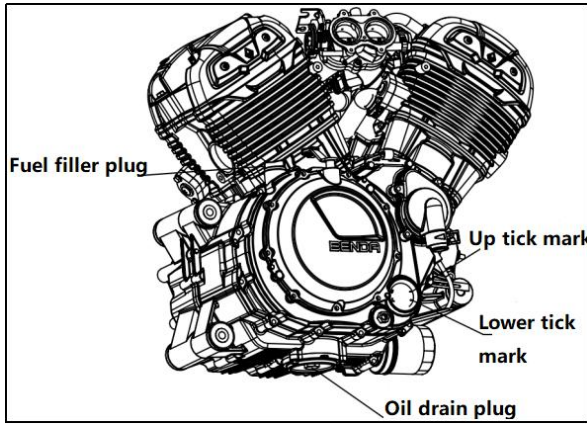

Fig 16 Lubricating oil inspection

SG Level	SAE10W-30
	SAE15W-40
	SAE20W-50

[Selection] (Fig18)

Lubricate oil grade:SAE 15W-40

Quality requirements for lubricating oil: SG level or above

The use of high-quality four stroke engine lubricating oil can prolong the engine life.

You need to choose according to Figure 18 and compare it with the local temperature situation at your discretion:

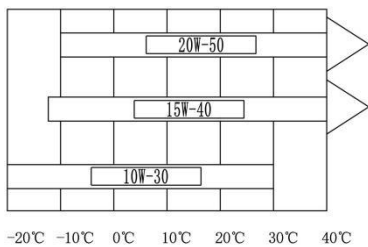

When the local temperature rises, lubricating oil with high viscosity, such as SAE15W-50, should be replaced;
When the local temperature drops, lubricating oil with low viscosity should be replaced, such asSAE10W-30.

[Replace]

Replace the new vehicle once at 1000km, the second time at 2000km, the third time at 3000km, and every 4000km thereafter.

1. After running the engine for 3 minutes, turn off the engine and place an oil container under the engine drain bolt.
2. Drain the engine lubricating oil after 3 minutes (be careful not to be scalded by the engine or lubricating oil). Unscrew the oil bolt, loosen the nut, and take out the machine filter cover, spring, filter element, etc.
3. After draining the oil, the drain bolts and filter cover must be cleaned thoroughly; Replace the filter element and check if the sealing ring is intact. If there is any damage, replace it with a new one; Then install the filter element, spring, sealing ring, and machine filter cover.
4. Inject approximately 2.6 L of new lubricating oil from the oil filling port; If a new filter element is replaced, 2.8 L of new lubricating oil is required; Check and confirm that there is no oil leakage, then install the oil filler plug.
5. Run the engine at different speeds for 3 minutes. During operation, check for leaks at the disassembled parts. Wait for

the engine to shut down for 3 minutes. In idle mode, if the oil level is still below the mark below the oil window, an appropriate amount of lubricating oil should be added. It is necessary to check again for any leaks.

⚠Warning:

1. The use of inferior lubricating oil can seriously affect the performance and lifespan of the engine.
2. Long term failure to change lubricating oil can cause deterioration, and deteriorated lubricating oil can cause excessive wear and tear on the engine and components.
3. If the lubricating oil is insufficient, it will seriously damage the engine.

Common causes of lubricating oil deterioration:

1. The lubricating oil temperature is too high and naturally deteriorates.
2. Lubricating oils with different labels are mixed together to deteriorate.
3. The metal shavings generated by the friction of the components are increasing.
4. There are many dust and impurities in the lubricating oil barrel.
5. The gap between the piston and cylinder is too large to leak exhaust gas, and carbon residue is generated during fuel combustion.

⚠Danger:

1. The exhaust pipes of engine lubricating oil and muffler can burn people. Before discharging the old lubricating oil, wait for the oil drain bolt and exhaust pipe to cool down.
2. Children and pets who accidentally drink lubricating oil can cause physical injury. Reiterating: Long term exposure to lubricating oil can lead to skin cancer. Short term exposure to lubricating oil can irritate the skin. Keep children and pets away from lubricating oil. When changing lubricating oil, to reduce skin irritation, please wear long sleeved clothes and protective gloves (such as gloves used when washing clothes). If the skin comes into contact with lubricating oil, wash thoroughly with soap and water. Clean clothes and cloths contaminated with lubricating oil.

⚠Attention:

Please dispose of discarded engine lubricating oil properly and do not pour it into the trash can or directly onto the ground to avoid polluting the environment. We suggest that you pack the waste oil into a sealed container and send it to the local recycling center

⚠Warning:

If the specified engine lubricating oil is not used, it may damage the engine.

6.3 Selection and replacement of spark plugs

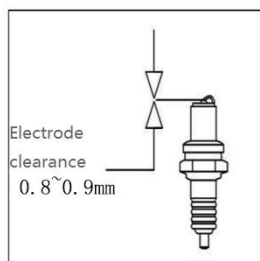

(Fig18)

Type: CR9EH-9 (NGK)

Spark plug sleeve opposite side: 16mm

[Check and replace]

1. The replacement cycle for spark plugs is around 6000 km.
2. Remove the spark plug cap, remove the surrounding dirt, use the spark plug socket wrench in the tool bag to remove

the spark plug, and use a wire brush to remove the carbon and dirt from the spark plug.

3. Check whether the spark plug is damaged, whether the electrode gap is burned, and whether the sealing gasket is intact; If there is damage, it should be replaced.

4. Check the electrode gap with a high-precision feeler gauge, and the normal electrode gap is 0.8-0.9mm.

5. When installing spark plugs: First, screw the spark plug into the thread by hand, and then tighten it with a spark plug socket wrench.

6.4 Cleaning and disassembly of air filters

[Clean or replace]

1. The element of the air filter must be regularly maintained: the filter element must be checked, cleaned, and adjusted in a timely manner every 40 hours or 1000km of driving; The air filter must be cleaned every 80 hours or 2000km of driving; The filter must be replaced with a new one every 20000km.

2. If the motorcycle is used in muddy, humid, or dusty environments, the cleaning or replacement cycle of the filter should be shortened.

3. If the filter element is too dirty, water ingress or damaged, it must be replaced with a new one, otherwise it will increase the intake resistance, decrease the engine output power, and increase fuel consumption. Keeping the air filter clean can improve the efficiency of the engine and extend its service life.

4. This motorcycle is a paper filter element. When cleaning, you can gently knock it on the ground to shake off most of the dust. If there is an air pump, you can blow it from the inside out to blow off the dust. If the filter paper is already dusty or wet with oil, water, etc., it must be replaced with a new filter element.

5. During regular maintenance, remove the oil accumulation pipe and drain the waste oil inside. The oil accumulation pipe is located under the air filter.

[Disassembly and assembly] (Fig20)

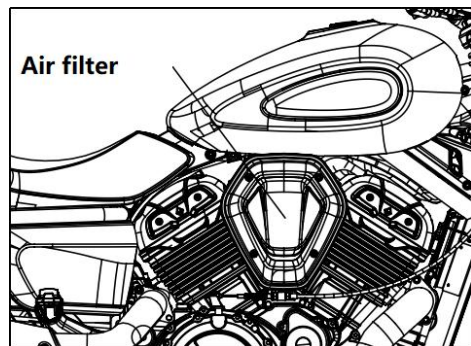

1. Remove the four screws on the side cover of the air filter and remove the fixing screws of the filter element. Remove the filter element.

2. Assembly: Follow the reverse order of the disassembly steps mentioned above.

Fig 19 Air filter position

Warning:

1. Starting the engine without installing a filter is very dangerous. Without the obstruction of the filter element, the engine flame will spray back into the air filter intake chamber from the engine, and dirt will also be sucked into the engine interior, causing serious wear and tear to the engine. Therefore, it is prohibited to start and run the engine without installing a filter element.

2. When washing the motorcycle, do not let water enter the interior of the air filter.

3. If the filter element is damaged, it must be replaced with a new one. When cleaning the air filter, the filter element must be checked for damage.

4. If the installation position of the filter element is incorrect, dust will bypass the filter element and enter the engine, damaging the engine. Confirm that the filter element is installed in the correct position and properly sealed.

6.5 Check and adjust of throttle handle

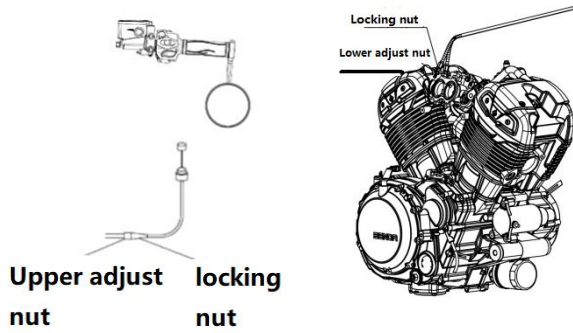

[Inspection] (Fig20)

1. Check if the front of the car is turning from the far left to the far right normally and if the limit is reliable.
2. Check if the rotation of the throttle control handle is flexible from the fully open position to the fully closed position; Can it automatically return to its original position when releasing the handle.
3. Check if the throttle cable is flexible and in good condition.

[Adjust]

1. The free stroke of the throttle handle is 2-6mm.
2. The upper adjustment screw can be fine tuned, and the lower adjustment screw (at the connection between the throttle valve and the throttle cable) can be adjusted to a certain stroke.
3. When making minor adjustments, first loosen the locking nut on the upper adjustment screw tube, and then rotate the upper adjustment screw tube for adjustment.
4. When making larger adjustments, loosen the fastening nut and adjust the free stroke to 2-6mm.
5. The throttle cable should be regularly lubricated to reduce the wear of the steel wire rope; Do not bend the throttle cable.

⚠ Danger:

1. The throttle cable is not properly routed and should be reinstalled correctly.
2. If the throttle cable is twisted, stuck or cannot return, the throttle control cable should be replaced.
3. After the free stroke adjustment of the throttle cable is completed, it is necessary to ensure that the throttle control handle can automatically return and the idle speed will not increase. After simultaneous adjustment, there should be no increase in engine idle speed when turning the front of the vehicle.

[Throttle body]

The throttle limit screw on the throttle body has been precisely set and cannot be adjusted by yourself. Check if the idle speed of the vehicle is stable (after the engine is fully preheated, the idle speed of the engine should be between 1350-1650RPM per minute). If the idle speed is unstable, please have our company's designated professional service personnel from the maintenance unit inspect and handle it.

6.6 Adjustment of clutch

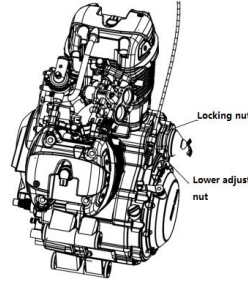
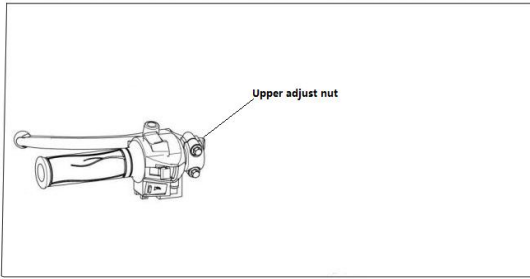

The free stroke of the clutch handle is 5-10mm.

The function of the clutch: (Fig 21)

1. Ensure a smooth and gentle combination between the engine crankshaft and the variable transmission system to ensure a smooth start of the motorcycle.
2. Enable the engine crankshaft to quickly and thoroughly separate from the variable transmission system to ensure that the motorcycle does not experience impact during gear shifting
3. It can prevent damage to components of the variable speed transmission system due to excessive load.

⚠Attention:

When using the clutch handle, you should fully grasp or fully release it; Try to avoid grabbing only half or releasing only half (using a semi clutch), otherwise it may cause clutch wear or burning.

VII、 Inspection and adjustment of belt

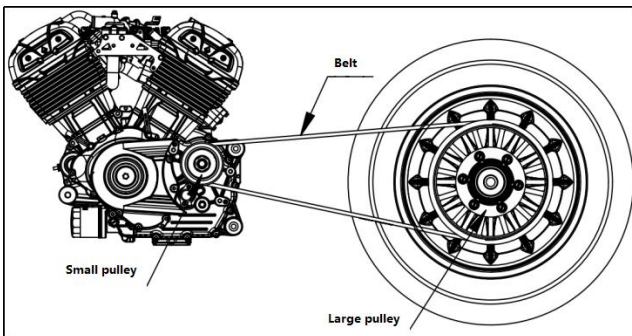

Type: 1881-H11M-30mm

[Inspection] (Fig22)

Before each ride, check if the belt drive system is working properly. If you notice any defects or damages, you must immediately inspect and repair them carefully. If necessary, replace the components of the transmission system, and the components can only be obtained from qualified dealers. Your dealer is able to identify any signs of wear and can replace necessary components. Therefore, if necessary, please bring the vehicle to the dealer for testing.

[Adjustment]

The installation tension of the belt needs to be checked using professional tools. If you need to check or adjust the belt tension, please go to the vehicle dealer and do not adjust it on your own.

[Replace]

1. Use tools to remove the large and small sprockets;
2. Install the large pulley, small pulley, and transmission belt in the opposite order of disassembly, and adjust the swing of the chain;
3. During the installation and debugging process of the belt, it should be noted that if the belt is not operated correctly, the tension rope may break,

This will cause the belt to lose its tensile strength and tear, posing a risk of failure!

- Avoid twisting, bending, twisting, knotting, or flipping the belt, and do not use it as a belt whip.
- Do not use a sprocket to lift the belt during installation.

- Do not use sharp edged tools to tamper with the belt.
- Do not oil or lubricate the belt.
- Do not attempt to open or repair the belt.

VIII、 ABS/Anti-lock braking system

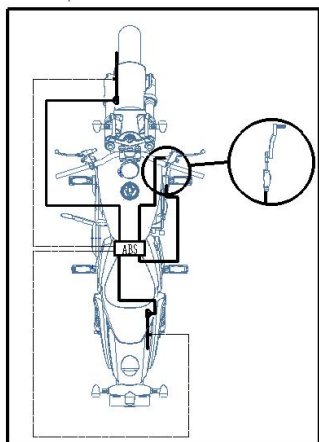

8.1、 ABS working principle

ABS consists of hydraulic unit, ABS control unit, and return pump, installed under the seat. There are two wheel speed sensors on the front and rear wheels.

ABS operates using two independent brake circuits (front brake and rear brake). In normal operating mode, the function of the braking system is the same as that of a conventional braking system without ABS. Only when the ABS control unit recognizes that a wheel is tending to lock up, will the ABS start working by adjusting the brake pressure. This adjustment process can be felt through slight jumps on the front brake handle or brake pedal.

After turning on the ignition switch, the ABS warning indicator light must light up and turn off after starting. If the ABS warning indicator light does not turn off after starting or lights up during driving, it indicates a malfunction in the ABS system. At this time, ABS cannot be activated again. The wheels may lock up when braking. The braking system itself still works, only the ABS adjustment system fails.

Warning:

- 1. Only when the ABS is in the off state can the rear wheels rotate when the front brake is tightened.**
- 2. If modifications are made, such as shortening or extending the shock absorption stroke, using other wheel rim diameters, using other tires, incorrect tire pressure, or using other brake friction pads, it may prevent ABS from continuing to function. Only when using spare parts and tires recommended by Benda Motors on the braking system can the optimal function of ABS be guaranteed.**
- 3. Please perform maintenance and repairs as required.**

8.2、 Turning off and on the ABS function

The ABS function defaults to the on mode. After pressing the ABS function switch for 3 seconds, the alarm light starts flashing at a frequency of 400ms. If the switch is released within 5 seconds, the ABS will switch to the off mode. When the ABS is in the off mode, the ABS warning light in the instrument panel flashes at a frequency of 1200ms. When the ABS is in the on mode, the alarm light will automatically turn off due to no faults.

Warning:

- 1. The activation of ABS function will provide maximum safety protection for cyclists during emergency braking.**
- 2. Please do not easily turn off the ABS function while cycling.**
- 3. Our company is not responsible for any consequences caused by cyclists turning off the ABS function while riding.**
- 4. After turning off the ABS function, turn on and off the switch lock again, and the ABS will return to the open state.**

IX、 Check and adjust of front brakes

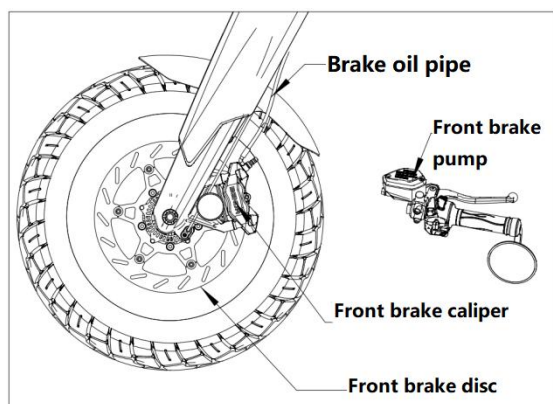

Fig24 Inspection of front brake

[Inspection] (Fig24)

- Measure the free stroke of the front brake handle to be 5-10mm.
 - Measure the thickness of the front brake disc and brake friction pad.
 - Check the oil level in the oil cup; Check if the brake caliper is functioning properly; Check the brake oil pipe and
- The brake oil cup has no oil leakage or cracks; Check the wear of the brake discs.
- When operating the brake handle, if you feel insufficient pressure on the handle, there is air in the brake system; The braking system should be completely emptied of air before it can be used normally; Otherwise, it will reduce braking performance or result in braking failure. This work should be completed at the BENDA specialty store.

⚠Warning:

1. Should add: non petroleum based brake oil with brand name DOT3 or DOT4; Different grades cannot be mixed for use;
2. Brake oil has strong corrosiveness and should not splash onto the surface of painted or plastic parts; If accidentally consumed, it should be forcibly vomited out; If it gets on the eyes or skin, immediately rinse with plenty of water and seek medical attention;
3. Hydraulic disc brakes operate under high pressure. To ensure safety and reliability, the replacement time of brake friction pads and brake oil should not exceed the maintenance cycle;
4. When the hydraulic disc brake system needs maintenance, it can only be repaired by professional technicians.

⚠Attention:

The brake is an extremely important component to ensure the personal safety of the rider, and it should be checked and adjusted regularly.

Replace with new brake discs or brake friction pads, do not drive immediately; You should first operate (grip) the front brake handle several times until the brake disc and brake caliper are well engaged.

9.1 Check the front brake discs

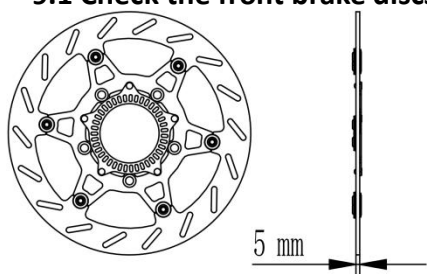

Fig25 Front brake disc inspection

The brake disc will gradually wear out during long-term use, so it is necessary to check the thickness dimension of the brake disc at multiple positions. And inspect its appearance to confirm whether the brake disc is damaged, cracked, or deformed.

If the thickness of the brake disc is lower than the specified value: please replace the brake disc.

If the brake disc is damaged, cracked, or deformed: please replace the brake disc

Brake disc wear limit	
Front	3mm
Rear	3mm

Warning:

The wear of the brake disc can reduce the thickness of the brake disc within the contact area of the brake friction plate, which will reduce the braking effect and pose a threat to your driving safety. Once damage, cracks, or deformation occurs, please replace the brake disc immediately.

When the brake disc is worn to the maximum thickness of 4mm, it must be replaced; Remove the front brake calipers and front wheels. and then replace the brake discs.

9.2 Check the brake pads of the front brake

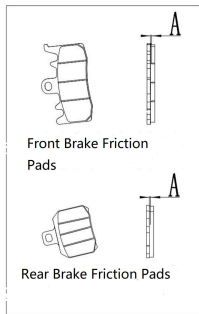

Check the minimum thickness of brake pads(A)

Minimum thickness: A=1.5mm.

If the thickness is lower than the minimum thickness: please replace the friction plate in a timely manner. If any damage or cracks are found on the friction plate, please replace it in a timely manner.

Fig26 Front brake friction pad inspection

Attention:

Friction pads will gradually wear out during vehicle braking. The braking effect will gradually decrease. To ensure your safety and that of the vehicle, please check regularly and replace it promptly. If you are not familiar with the specifications of the friction plate or cannot replace it on your own, please go to the designated after-sales point of BENDA for repair.

9.3 Check the brake fluid level of the front brake system

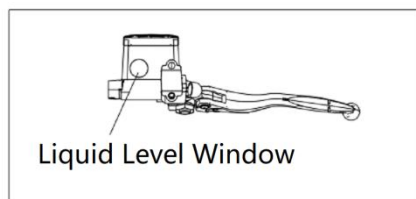

Adjust the vehicle's placement posture so that the brake fluid in the brake fluid tank is in a horizontal position, and check the brake fluid level through the fluid level window.

When the brake fluid level is below the mark, please replenish the brake fluid in a timely manner.

Fig27 Front brake fluid level check

X、 Check and adjustment of rear brake

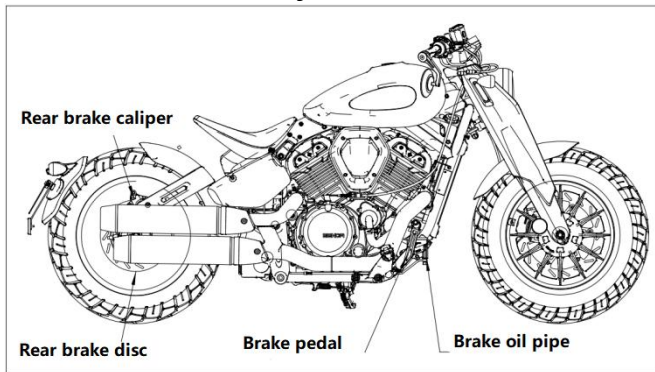

[Check] (Fig28)

- Measure the free stroke of the rear brake pedal to be 10-20mm.
 - Measure the thickness of the rear brake disc and brake friction pad.
 - Check the oil level in the oil cup; Check if the brake caliper is functioning properly;
 - Check for oil leakage or cracks in the brake oil pipe and brake oil cup; Check the wear of the brake discs.
- When operating the brake pedal and feeling insufficient pedal pressure, there is air in the brake system; The braking system should be completely emptied of air before it can be used normally; Otherwise, it will reduce braking performance or result in braking failure. Please have the professional technical personnel of the repair unit serve you for this repair.

10.1 Check rear brake disc

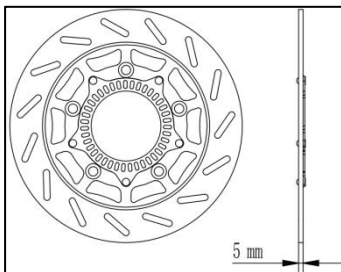

Fig19 Rear brake disc inspection

The brake disc will gradually wear out during long-term use, so it is necessary to check the thickness dimension of the brake disc at multiple positions. And inspect its appearance to confirm whether the brake disc is damaged, cracked, or deformed.

If the thickness of the brake disc is lower than the specified value: please replace the brake disc.

If the brake disc is damaged, cracked, or deformed: please replace the brake disc.

Brake disc wear limit	
Front	3mm
Rear	3mm

Warning:

Brake disc wear will reduce thickness of brake disc within the contact area of the brake friction pads and also reduce braking effect to have a threaten to you. Once damage, cracks, and deformation occur, please replace the brake discs immediately. When the brake disc is worn to the maximum thickness of 3mm, it must be replaced; Remove the rear brake calipers and rear wheels, then replace the brake discs.

10.2 Check the brake pads of the rear brake

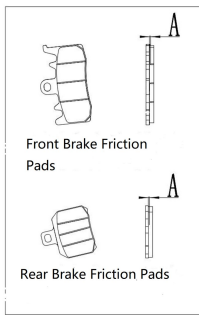

Check the minimum thickness (A) of the brake friction plate.

The minimum thickness value of the brake friction plate is $A=1.5\text{mm}$.

If the thickness is lower than the minimum thickness: please replace the friction plate in a timely manner.

If any damage or cracks are found on the friction plate, please replace it in a timely manner

Fig30 Rear brake disc inspection

⚠Attention:

Friction plates will gradually wear out during vehicle braking. The braking effect will gradually decrease. To ensure your safety and that of the vehicle, please check regularly and replace it promptly. If you are not familiar with the specifications of the friction plate or cannot replace it on your own, please go to the designated after-sales point of BENDA for repair.

10.3 Check the brake fluid level of the rear brake system

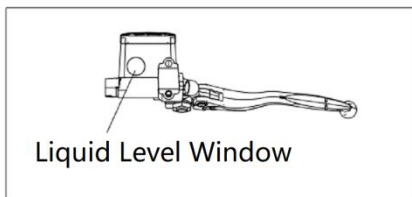

Fig31 Rear brake fluid level check

Adjust the placement posture of the vehicle so that the brake fluid in the brake fluid filling is in a horizontal position, and check the brake fluid level through the liquid level window.

When the brake fluid level is below the scale mark: please replenish the brake fluid in time.

⚠Warning:

If the brake fluid level is below the mark, it means that the brake system is not sealed or the brake friction pads are completely worn. Check the brake system and do not continue driving. Please go to the designated after-sales point of BENDA for repair.

Excessive use of brake fluid can reduce braking effectiveness. Please replace the brake fluid in a timely manner.

XI、 Battery maintenance

[Model]

Type: MG14ZS-C

Capacity: 12V 11.2Ah

Standard charge: 1A~1.5A×6~8hours

[Disassembly and assembly of battery] (Fig33)

Dismantle:

1. Open the seat cushion lock and remove the seat cushion;
2. Open the battery box cover;
3. Remove the ECU bracket;
4. First, remove the negative electrode wire (-);
5. Remove the positive electrode wire (+) afterwards;
6. Remove the battery.

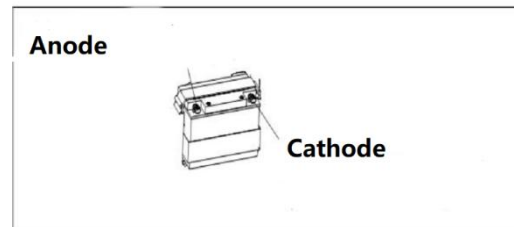

Install:

1. The installation sequence is opposite to the disassembly steps

2. First install the positive wire (+), then install the negative wire (-), and ensure that it is positive and negative

The terminal block is not loose, and the positive and negative terminals cannot be reversed. Reverse connection can damage electrical components.

[Battery charging]

1. Remove the seat cushion.
2. Remove the battery tie, remove the positive and negative wires, and take out the battery
3. Connect the charger wire and ensure that the charging current is 1/10A of the battery capacity. For example, if a battery with a capacity of 10Ah is charged, its charging current is 1 ampere.
4. For detailed instructions on the charger, please contact your dealer.

[Inspection and maintenance of batteries]

- 1 When frequently used, the motorcycle charging system automatically charges the battery fully. If you occasionally use a motorcycle or use it for a short period of time, the battery may be low. The battery will generate self discharge, and the self discharge rate varies with the type of battery and ambient temperature.
- 2 When the motorcycle is not used for a long time, the battery must be removed for charging and stored, and the battery must be charged regularly;
- 3 The positive (+) and negative (-) battery terminals should be cleaned regularly.
- 4 When replacing the battery, the same type and specification of battery should be used.

⚠ Danger:

Battery terminals, terminals, and related components contain lead or lead compounds. If lead or lead compounds enter the blood system, they can harm your health. After contact with pollution, they must be cleaned promptly.

2. The battery must be stored out of reach of children.

3. Batteries contain toxic substances such as sulfuric acid and lead. It can cause harm to people and pollute the environment. Used batteries must be disposed of or recycled in accordance with local legal regulations. It cannot be discarded like ordinary household waste.

 Attention:

1. Overcharging or undercharging the battery can shorten its lifespan. Do not let the battery overcharge or undercharge.
2. If your vehicle is rarely driven, you must use a voltmeter to check the battery voltage every week. If the voltage of the battery is below 12.8V, a charger must be used to charge the battery.
3. If you do not use the vehicle for more than two weeks, you must use a charger to charge the battery. Do not use an automatic fast charger to charge the battery, as this can cause overload and damage to the battery.

[Replacement of fuses]

There are a total of six plug-in fuses in the circuit system, including 4PCS of 20A fuses, 1PCS of 10A-ECU fuses, and 1PCS of 5A-ABS fuses, totaling 6PCS. In addition, there are 2 additional 20A fuses and 1 10A fuse inside the fuse box. If the fuse frequently burns out, there may be a short circuit or overload in the circuit system. Please have professional technicians from the maintenance unit serve you.

When replacing a fuse, first unplug the old fuse and plug in a spare fuse.

 **Warning:**

Before checking or replacing fuses, the ignition switch and electrical switches must be turned off to prevent circuit shorts. Never use a fuse with a current rating that is different from the rated current, otherwise it may cause damage to the vehicle's electrical system or cause a fire. It may also pose a risk of lighting failure or engine failure at night or during driving.

XII、 Engine water cooling system maintenance instruction

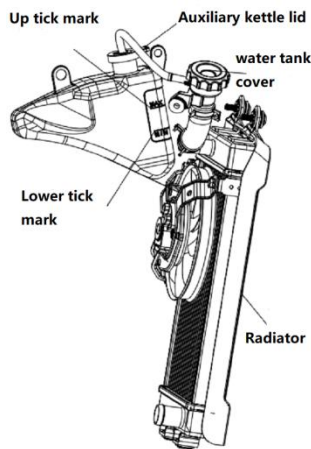

[Cooling system] (Fig33)

The cooling system can prevent engine overheating, and proper use and maintenance of the cooling system can extend the service life of the engine.

The radiator is located at the front of the engine and should be regularly cleaned of dust and soil according to the road conditions you are driving on.

Fig3 Cooling system

[Type of coolant]

The coolant has five characteristics: corrosion prevention, cavitation prevention, high boiling point, anti scaling, and anti freezing.

Cooling liquid is generally mixed with concentrated antifreeze and soft water (purified or distilled water) in an appropriate proportion. Please mix it into a fixed concentration that adapts to the local minimum temperature. Generally, when mixed into a concentration of 40% to 50%, the antifreeze function is the best.

The direct coolant specially used for aluminum alloy engine is used. This coolant has been prepared in the factory and contains Antifreeze, rust inhibitor, foam inhibitor and trace silicate. The ambient temperature for use is indicated on the container.

⚠ Attention:

- 1. This coolant is a specialized coolant and cannot be replaced with tap water or other liquids, as it may cause engine damage.**
- 2. Please go to the "BENDA Exclusive Store" to purchase direct coolant for aluminum alloy engines.**
- 3. If you need to replace the coolant or if there is a coolant leak, please go to the "BENDA Exclusive Store" for replacement and repair.**

[Check the coolant capacity]

The total amount of coolant in the cooling system is approximately 2000ml

1. Park the motorcycle on a flat surface with a single support.
2. Check the coolant level while the engine is cooling, and the coolant level should be between the upper and lower markings.

[Add small amount coolant]

If the coolant in the auxiliary water tank is at or below the lower mark position, please add special coolant in a timely

manner to the upper mark position.

[Add method]

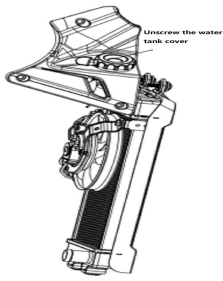

1. Park the motorcycle on a flat surface with a single support and wait for the engine to cool down; Otherwise, heat may cause burns to the skin;
2. Unscrew the water tank cover and the auxiliary kettle cover; Install the water tank cover and auxiliary kettle cover.
3. Pour the coolant into the water tank and add it to the upper mark position;
4. Cover the water tank cover and the auxiliary kettle cover.

Fig34 Adding coolant

[Storage of the coolant]

1. When the coolant is not in use, it should be stored in a dedicated sealed container.
2. It should be placed in a cool and dry place. The coolant is a toxic liquid and must be kept away from children.
3. Pay attention to the strict prevention of contamination of the coolant by petroleum products, and do not mix or store two different brands of coolant

⚠ Danger:

1. Antifreeze is an organic solvent with toxicity and corrosive. During use, it is not allowed to splash onto the surface of rubber products or paint parts, nor should it come into contact with human skin. If it accidentally splashes onto rubber products, paint surfaces, or human bodies, it should be immediately rinsed with water.
2. When repairing the engine, if it is necessary to loosen the cylinder nut, please drain the coolant first to prevent it from entering the crankcase.
3. Due to the higher boiling point of antifreeze compared to pure water, the radiator cap must not be opened when the engine is running normally or the temperature has not dropped (60 °C) after parking to avoid burning the body.

XIII、 Vehicle cleaning and storage

[Vehicle cleaning]

1. Motorcycles should be cleaned regularly to detect damage, wear, or oil leakage in a timely manner.
2. When cleaning, it is necessary to wait for the engine to cool down and rinse with clean water. After cleaning, dry the motorcycle and start the engine, allowing it to run for a few minutes; Use lubricating oil to lubricate the chain; Before driving on the road, check the brakes, and the front and rear brakes should be normal.
3. Parts that cannot be sprayed with high-pressure water: headlights, turn signals, ignition lock, electrical switches, instruments, electrical parts and circuits, batteries, air filters, wheel hubs, exhaust pipe outlets, under the fuel tank, and engine cylinder heads. These components are best wiped with a cloth.

4. The braking performance may decrease after cleaning, and it must be tested and adjusted before use.

[Vehicle storage]

After the motorcycle is used on the same day, it should be stored in a dry, small temperature difference, and well ventilated safe place. If stored for a long time (over 30 days), necessary repairs should be carried out before storing the motorcycle; Otherwise, problems that require repair may be forgotten when using after storage. Long term storage (over 30 days) should not only be repaired according to the above requirements, but also be maintained according to the following requirements:

1. Clean and dry the motorcycle, and apply wax to the painted surface of the entire vehicle.
2. Drain the fuel from the fuel tank and spray rust inhibitor into the tank.
3. Completely drain the oil and refill the crankcase with new oil.
4. Remove the spark plug and inject a small amount (15-20 milliliters) of lubricating oil into the cylinder; Then reinstall the spark plug, open the ignition switch lock, press the start button for 2-3 seconds, and evenly distribute the oil on the cylinder wall.
5. Remove the battery, remove rust from the terminals and wiring connectors, and store in a well ventilated, dry, cool, and away from direct sunlight.
6. Inflate the tires to the specified pressure and place the motorcycle above the cushion blocks, so that the front and rear wheels are off the ground. If the tire pressure is too low, it will cause premature aging and cracking of the tires.
7. Cover the intake port of the air filter and the exhaust port of the exhaust muffler with a cloth containing new engine oil to prevent moisture from entering.
8. Cover the motorcycle with highly breathable materials and store it in a dry, safe place with low temperature difference and good ventilation.

[Use after vehicle storage]

1. Remove the motorcycle cover and clean the motorcycle.
2. Check the voltage of the battery. If the voltage is below 12.8V, it must be charged at low speed before installing the battery.
3. Remove the rust inhibitor from the fuel tank and add new fuel.
4. Test drive the motorcycle in a safe place to check whether its performance is normal.

XIV、 The service life and vehicle handling of vehicles

[Vehicle service life]

Please follow the rules and regulations of the traffic management department or the local vehicle management office for the duration of the vehicle's use.

[Vehicle handling]

1. Disposal of used engine oil: The used engine oil under the motorcycle replacement should be put into a plastic bucket and handed over to the recycling company for disposal. You can't discharge the used engine oil at will, otherwise it will cause damage to the site, soil, water source and other environment.
2. Disposal of used batteries, light bulbs, exterior parts, filter elements, tires, iron parts, aluminum parts and other parts:

these end-of-life parts should be classified and recycled. You can't just throw them away, and you can't dump the diluted sulfuric acid in the battery and cause harm to people or pollution to the environment.

3.After the vehicle is scrapped, please handle it according to the vehicle scrapping regulations of the traffic management department or local vehicle management office.

XV、 Adjustment data related to motorcycles

Front (handbrake) free stroke 5-10mm

Free clearance of throttle handle: 2-6mm

Rear (foot) brake free stroke 10-20mm

Free stroke of clutch: 5-10mm

Spark plug gap: 0.8-0.9mm

Gap between intake and exhaust valves: 0.08~0.12 mm

Rear shock absorber fastening bolt torque value: 30-40 N · m

Torque value of the handle fastening bolt: 4-6 N · m

Torque value of the flat fork shaft fastening nut: 70-90 N · m

Front wheel axle fastening nut torque value: 70-90N · m

Steering system fastening nut torque value: 50-70 N · m

Rear wheel axle fastening nut torque value: 70-90 N · m

Front shock absorber and upper connecting plate fastening bolt torque value: 10-14N · m

Front shock absorber and steering column fastening bolt torque value: 20-25 N · m

Engine suspension fastening nut torque values: M8:18-25 N · m, M10:30-40 N · m

XVI、 Table of Main technical parameters

Model name		BD500-30
Vehicle parameters	Manufacturer Name	HANGZHOU SATURN TECHNOLOGY CO,.,LTD
	Vehicle model (commercial name)	BD500-30
	Vehicle brand	(BENDA)
	Vehicle type	Ordinary two wheeled motorcycle
	Vehicle identification number	H84PDTPExxxxxxx
	Authorized passenger capacity	One person (One driver and one passenger each)
	Turning form	Directional handle
	Gear format	Sixth gear constant engagement
	Braking form	Front wheel: disc type Rear wheel: disc type
	Braking operation mode	Front wheel: Hand brake Rear wheel: Foot brake
	Clutch form	Oil bath multi plate type
	Starting method	Electric start
	Length * Width * Height	2260*846*1183
	Wheelbase	1545
	Minimum ground	153

	clearance	
	Vehicle curb weight	196
	Maximum load capacity mass	75
Model		BD500-30
Vehicle parameters	Fuel tank capacity	16L
	Number of tires	2
	Front wheel specifications	150/80-16
	rear tire	180/65-16
Electrical installations	Ignition method	ECU
	Spark plug model	CR9EH-9
	Headlamp specifications	12V LED
	Turn signal specifications	12V LED
	Tail/brake light specifications	12V LED
	fuse value	20A(6)、10A(1)、5A(1)
	Battery specifications	12V 11.2Ah
Engine	Engine form	V-shaped twin cylinder
	Engine model	BD2V69MR
	Compression ratio	11.5: 1
	Actual displacement	475.6ml
	Maximum net power	35kw/8800rpm
	Maximum torque	42N.M/6700rpm
	Bore * stroke	69*63.6
	idling	1500±150
	Engine lubricating oil	SAE
	Brand	10W-40
	Lubricating oil capacity	2.8L
	Fuel grade	92 # or above gasoline
	Spark plug gap	0.8~0.9 mm
Ratio	Primary speed ratio	2.16
	First gear ratio	3.23
	Second gear ratio	2.12
	Third gear ratio	1.57
	Fourth gear ratio	1.33
	Five speed ratio	1.13
	Six speed ratio	1.04
	Final speed ratio	2.89
Performance	Maximum speed	150
	Fuel consumption	≤5L/100km

XVII、 Common motorcycle troubles and causes

Phenomenon	Part location	Causes	Ways	
Can not start	Fuel system	There is no fuel in the fuel tank	come on	
		Oil pump blockage or damage, poor fuel quality	Cleaning or replacement	
	Ignition system	Spark plug malfunction: Excessive carbon buildup and prolonged use	Check or replace	
		Spark plug cap malfunction: poor contact or burnt out	Check or replace	
		Ignition coil malfunction: poor contact or burnt out	Check or replace	
		CDI malfunction: poor contact or burnt out	Check or replace	
		Trigger coil malfunction: poor contact or burnt out	Check or replace	
		Stator fault: poor contact or burning	Check or replace	
		Cylinder pressure system	Fault in each connecting line: poor contact	Check or adjust
	Starting mechanism malfunction: worn or damaged		Check or replace	
	Malfunction of intake and exhaust valves and valve seats: Fuel contains too much gum or has been used for too long		Check or replace	
	Cylinder, piston, and piston ring malfunction: Fuel contains gum or is worn		Check or replace	
	Air intake pipe leakage: used for too long		Check or replace	
	Insufficient power	Valve piston	Excessive carbon deposits on the intake and exhaust valves and pistons: poor fuel quality, poor oil quality	Repair or replace
		clutch	Clutch slipping: poor oil quality, prolonged use, overload	Adjust or replace
Cylinder block and ring		Wear of cylinder block and piston rings: poor oil quality and prolonged use time	Oil Change	
Brakes		Incomplete brake release: brake too tight	adjustment	
chain		Chain too tight: improper adjustment	adjustment	
engine		Engine overheating: The mixture is too rich or too thin, and the quality of the engine oil and fuel is poor,	Adjust or replace	
spark plug		There are obstructions, etc	Adjust or replace	
Intake pipe		Improper spark plug gap, normal 0.8-0.9 mm	Adjust or replace	
Cylinder head		Air leakage in the intake pipe: adjusted or replaced after prolonged use	Check or replace	
Electrical system		Cylinder head or valve leakage	Inspect or repair	
Air filter	Electrical system malfunction	Cleaning or adjusting		
Headlamps and tail lights do not light	cable	Poor wiring connection	adjustment	
	Left and right switches	Poor or damaged switch contact	Adjust or replace	

up	Headlamps	Inspection of light bulbs and lamp holders	Adjust or replace
Headlamps and tail lights do not light up	Voltage regulator	Voltage regulator inspection: poor contact or burnt out	Check or replace
	Magneto	Magnetic motor coil inspection: poor contact or burnt out	Check or replace
The horn does not sound	Battery	The battery is dead	Adjust or replace
	Left switch	Horn button inspection	Adjust or replace
	cable	Poor circuit contact	Adjust or replace
	horn	Damaged horn	Adjust or replace

The above are common malfunctions of motorcycles. If your motorcycle malfunctions, please go to the designated repair unit for inspection and repair in a timely manner.

DE08 Fault code table	
Fault code	Description
P 0118	Cylinder temperature sensor circuit high voltage/open circuit
P 0117	Low voltage in the cylinder temperature sensor circuit
P 0336	Interference in the signal of the crankshaft position sensor circuit
P 0335	No signal from the crankshaft position sensor circuit
P 2301	Short circuit of ignition coil "A" to high voltage (cylinder 1)
P 2300	Short circuit of ignition coil "A" to low voltage (cylinder 1)/open circuit
P 2304	Short circuit of ignition coil "B" to high voltage (cylinder 2)
P 2303	Short circuit of ignition coil "B" to low voltage (cylinder 2)/open circuit
P 0123	The throttle position sensor is short circuited to high voltage
P 0122	Short circuit to low voltage/open circuit of throttle position sensor
P 0459	Carbon canister solenoid valve circuit short circuited to high voltage
P 0458	Carbon canister solenoid valve circuit short circuit to low voltage/open circuit
P 0232	Oil pump relay short circuited to high voltage
P 0231	Oil pump relay short circuited to low voltage/open circuit
P 0601	ECM read-only memory verification error
P 0262	Cylinder 1 injector short circuited to high voltage
P 0261	Cylinder 1 injector short circuited to low voltage/open circuit
P 0265	Cylinder 2 injector short circuited to high voltage
P 0264	Cylinder 2 injector short circuit to low voltage/open circuit
P 0108	High voltage in the intake pressure sensor circuit
P 0107	Low voltage/open circuit in the intake pressure sensor circuit
P 0113	High voltage/open circuit in the intake temperature sensor

	circuit
P 0112	Low voltage in the intake temperature sensor circuit
P 0650	Engine malfunction indicator light malfunction
P 0132	Short circuit to high voltage/open circuit of the oxygen sensor in front of cylinder 1
P 0131	The oxygen sensor in front of cylinder 1 is short circuited to ground
P 0031	Cylinder 1 front oxygen sensor heater short circuited to low voltage/open circuit
P 0032	Cylinder 1 front oxygen sensor heater short circuited to high voltage
P 0138	Short circuit to high voltage/open circuit of the oxygen sensor in front of cylinder 2
P 0137	The oxygen sensor in front of cylinder 2 is short circuited to ground
P 0037	Cylinder 2 front oxygen sensor heater short circuited to low voltage/open circuit
P 0038	Cylinder 2 front oxygen sensor heater short circuited to high voltage
P 0563	High system voltage
P 0562	Low system voltage
P 0500	Vehicle speed sensor malfunction
P 0505	Idle control malfunction

The above are common fault codes for motorcycles. If your motorcycle malfunctions, please go to the designated repair unit for inspection and repair in a timely manner.

Remember: You cannot handle motorcycle malfunctions on your own, otherwise it may cause safety hazards or accidents. If you handle motorcycle malfunctions on your own and cause safety accidents, you are solely responsible.

XVIII、BD500-30 Electrical schematic diagram

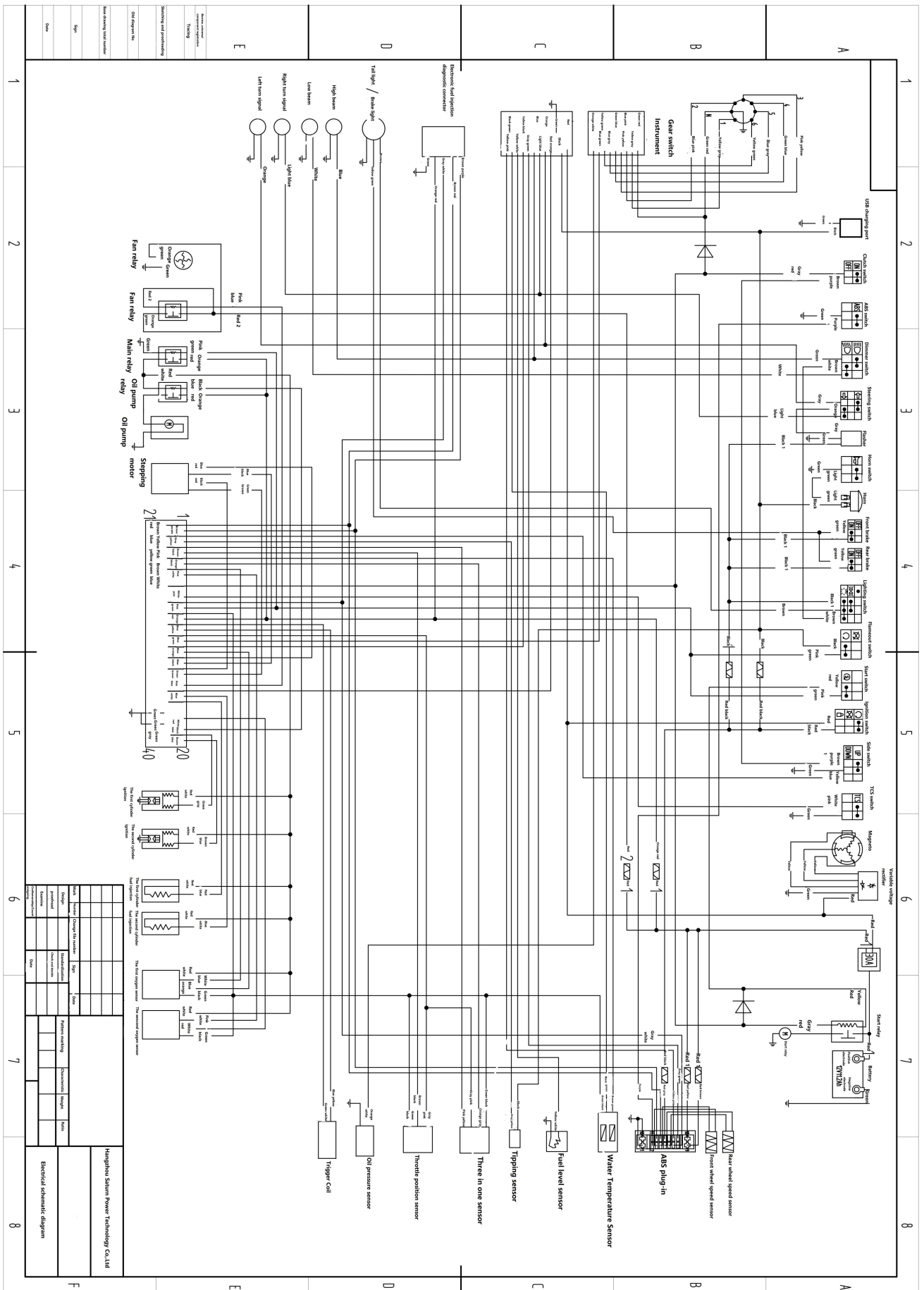

Symbol	Legend
[Symbol]	Water Temperature Sensor
[Symbol]	Front wheel speed sensor
[Symbol]	Rear wheel speed sensor
[Symbol]	ABS plug-in
[Symbol]	Water Temperature Sensor
[Symbol]	Fuel level sensor
[Symbol]	Tipping sensor
[Symbol]	Three in one sensor
[Symbol]	Throttle position sensor
[Symbol]	Oil pressure sensor
[Symbol]	Trigger coil
[Symbol]	Start relay
[Symbol]	Magneto
[Symbol]	Side switch
[Symbol]	Ignition switch
[Symbol]	Start switch
[Symbol]	Forward switch
[Symbol]	Lighting switch
[Symbol]	Front brake
[Symbol]	Rear brake
[Symbol]	Horn switch
[Symbol]	Filter
[Symbol]	Steering switch
[Symbol]	Engine switch
[Symbol]	ABS switch
[Symbol]	Cruise switch
[Symbol]	USB charging port

Hinguhou Sium Power Technology Co., Ltd
 Electrical schematic diagram

